

## Fine mapping of the grain chalkiness QTL *qPGWC-7* in rice (*Oryza sativa* L.)

Lijun Zhou · Liangming Chen · Ling Jiang · Wenwei Zhang ·  
Linglong Liu · Xi Liu · Zhigang Zhao · Shijia Liu · Lujun Zhang ·  
Jiankang Wang · Jianmin Wan

Received: 30 January 2008 / Accepted: 24 October 2008 / Published online: 20 November 2008  
© Springer-Verlag 2008

**Abstracts** Chalkiness of rice grain is an important quality component of rice, as it has a profound influence on eating and milling qualities. We have determined the inheritance of percentage of grain with chalkiness (PGWC) using a set of chromosome segment substitution lines, made from a cross between cv. PA64s and cv. 9311. Two loci controlling PGWC, designated as *qPGWC-6* and *qPGWC-7*, were located on, respectively, chromosomes 6 and 7. Comparisons were made between C-51 (a CSSL harbouring *qPGWC-7* and having a chalky endosperm) and the recurrent parent 9311 (translucent endosperm) to characterize the physical and chemical differences between translucent and chalky endosperm. Unlike the translucent endosperm, the chalky endosperm contains loosely packed starch granules, and there were significant difference between C-51 and 9311 for amylopectin structure and degree of crystallinity, but not for either amylose content or starch viscosity. Segregation analysis of the F<sub>2</sub> population from the cross between C-51 and 9311 showed PGWC is a semi-dominant trait, controlled by single nuclear gene. A large F<sub>2</sub> population was constructed from the cross C51 × 9311, and used for the fine mapping of *qPGWC-7*, which was located to a 44-kb DNA fragment, containing

thirteen predicted genes. This result provides a springboard for the map-based cloning of *qPGWC-7* and allowed for marker-assisted selection for endosperm texture.

### Introduction

Grain chalkiness is an undesirable character, as it is associated with high levels of damage to the kernel during milling, and thus to a reduction in head rice recovery (Del Rosario et al. 1968). Furthermore, when chalky grain is steamed or boiled, cracks develop readily, reducing the palatability of the cooked product (Nagato and Ebata 1959; Cheng et al. 2005). Thus, the presence of more than 20% chalky kernels is not generally acceptable in most world markets. On the other hand, chalky grain is optimal for the production of special products, notably Japanese sake. Therefore, breeding for the appropriate endosperm type has to be considered in the context of market requirements.

Scanning electron microscope (SEM) analysis has shown chalky endosperms are filled with loosely packed, round and large compound starch granules, while translucent endosperms have tightly packed, polyhedral and small single starch granules (Kang et al. 2005; Singh et al. 2006; Fujita et al. 2007; Yamakawa et al. 2007). The presence of large air spaces between starch granules (Singh et al. 2006) result in significantly different physico-chemical, morphological, thermal, cooking and textural properties compared to those of translucent grains (Singh et al. 2003; Cheng et al. 2005).

Chalkiness in rice, including white belly and white core (Satoh and Omura 1981; Tan et al. 2000; Li et al. 2004), is under genetic control, but its extent can be affected by the weather conditions experienced during the grain filling

Communicated by M. Morgante.

L. Zhou · L. Chen · L. Jiang · W. Zhang · L. Liu · X. Liu ·  
Z. Zhao · S. Liu · L. Zhang · J. Wan (✉)  
State Key Laboratory of Crop Genetics and Germplasm  
Enhancement, Jiangsu Provincial Center of Plant Gene  
Engineering, Nanjing Agricultural University,  
210095 Nanjing, China  
e-mail: wanjm@njau.edu.cn

J. Wang · J. Wan  
Institute of Crop Sciences, Chinese Academy of Agricultural  
Sciences, 100081 Beijing, China

period (Yamakawa et al. 2007). Its inheritance has been shown to be complex (Shi et al. 2002), and so if marker-assisted selection (MAS) strategies are to be applied for (or against) this trait, it is necessary to identify and mark the major quantitative trait loci (QTL) involved in trait determination. Several QTL have been described as controlling percentage of grains with chalkiness (PGWC), located on chromosomes 1, 5–10 and 12 (Koh et al. 1999; He et al. 1999; Tan et al. 2000; Li et al. 2004, 2003; Huang 2006). Of these, three (mapping to chromosomes 1, 8, 9) have been shown to be stably expressed over eight environments, and have therefore provided a firm basis for a MAS programme. Two genes, *OsPPDKB* and starch synthase IIIa (*SSIIIa*), also have pleiotropic effects on white-core endosperm in rice (Kang et al. 2005; Fujita et al. 2007). The former encodes pyruvate orthophosphate dikinase (PPDK), which contributes to the control of carbon flow into starch and lipid biosynthesis during grain filling (Kang et al. 2005); while the latter (*SSIIIa*) plays an important role in the elongation of amylopectin chains (Fujita et al. 2007). No gene associated with the white-belly endosperm trait has been yet identified.

The rice super-hybrid PA64s/9311 has occupied a greater area in China than any other single variety over the past 5 years. In this study, a set of chromosome segment substitution lines (CSSL) created using 9311 as the recurrent and PA64s as the donor, was used to investigate the genetic basis of chalkiness. The objectives of this study were: (1) to detect major QTL affecting chalkiness in this population, (2) to analyze the physical and chemical characterization of a CSSL with major QTL for chalkiness, and (3) to fine map a stable QTL and identify tightly linked microsatellite (SSR) markers by using secondary F<sub>2</sub> populations derived from a cross between the target CSSL and the recurrent parent.

## Materials and methods

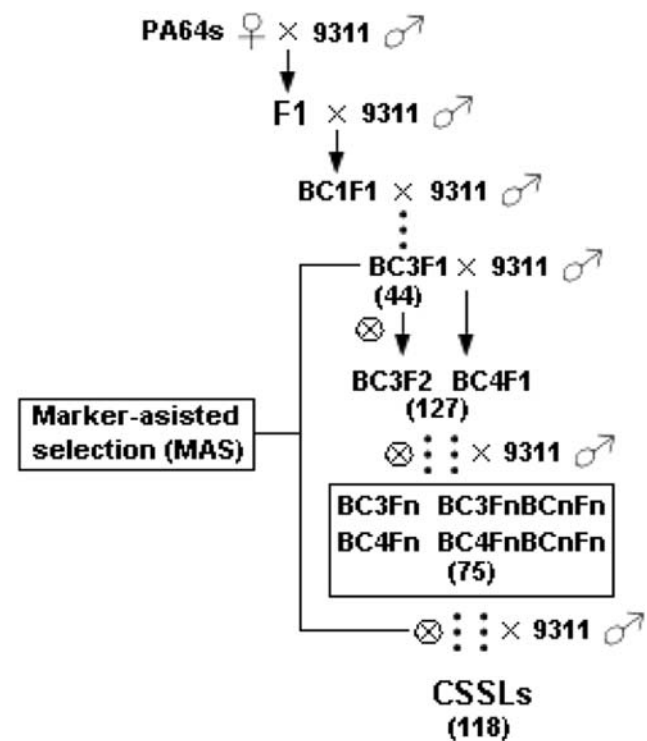
### Plant materials and fine mapping population

The recurrent parent 9311 is the *indica* rice which was used for genome sequencing (Yu et al. 2002), and the donor PA64s is a thermo-sensitive genic male sterile line with a broad spectrum of wild compatibility. The lines differ significantly with respect to PGWC. The original PA64s/9311 CSSL population consisted of 75 lines (Xiao et al. 2005), of which a few retaining some heterozygosity have since been subjected to further selection to produce a fixed population of 118 CSSL (Fig. 1). The selection was based on allele calling at 202 SSR loci distributed evenly across all 12 rice chromosomes. Two QTL were detected in the PA64s/9311 CSSL population. One was *qPGWC-7*, present

in three CSSL (C-51, 52, 62). To fine map this QTL, C-51 was used to build a secondary F<sub>2</sub> population by backcrossing to 9311 and self-pollinating, and 400 extreme phenotype individuals were selected from a sample of 2,108 plants. To these were added a further 2,821 (selected from 5,965). Thus the size of the fine mapping population was 3,221.

### Field experiment design and conduction

The two parents and their 118 CSSL were grown in the experimental field of the Jiangsu Academy of Agricultural Sciences, Nanjing, China in 2006. Each plot consisted of four rows of ten plants each, arranged in a randomized block design with two replicates. The 2108 F<sub>2</sub> plants and 9311 and three target CSSL (C-51, 52, and 62) were planted in Hainan, China in the winter of 2006, and a further 5,965 plants, along with 9311 and three target CSSL, was grown at Nanjing Agricultural University, Nanjing, China in the 2007 rice-growing season. At maturity, each CSSL was harvested as a bulk, while each F<sub>2</sub> plant was harvested separately. After drying, grains were stored at room temperature for 3 months, and then dehulled and scored for PGWC.



**Fig. 1** The strategy for developing the chromosome segment substitution lines (CSSL) population with the genetic background of *Indica* variety 9311. ⊗, × denote, respectively, self-fertilization and backcrossing

## Trait measurement

PGWC were evaluated according to He et al. (1999) and NSPRC (1999). To separate chalky from vitreous grains, three replicates of 100 grains per entry were assessed on a chalkiness visualizer constructed at the China National Rice Research Institute (NSPRC 1999). The mean percentage of chalky grains represented the PGWC score for that line.

For observation of endosperm cross-section, rice seeds were dried completely under low pressure and cut across the short axis with razor blade. The surface was sputter-coated with gold and observed by SEM (SEM, Hitachi S-3000N).

X-ray diffraction patterns of starch granules were obtained on a Shimadzu X-ray powder diffractometer (D/max-B, Rigaku, Japan). The diffracted intensity (in counts) was measured as a function of  $2\theta$ . The starch, saturated with water, was layered on a sample holder and scanned from  $3^\circ$  to  $40^\circ$ . The X-ray generator ran at 35 kV and 20 mA. The other operation conditions were as follows: step interval  $0.02^\circ$ , scan rate  $2^\circ/\text{min}$ , sollet and divergence slit  $1^\circ$ , receiving slit  $1^\circ$ , and scattering slit  $0.15^\circ$ . The degree of crystallization of starch was estimated by  $I_c/(I_a + I_c) \times 100$  (Fujita et al. 1998; Cheetham and Tao 1998), and calculated by XRD pattern processing software Jade5.0 (Materials data, Inc.). ( $I_a$  is the amorphous area, and  $I_c$  the crystallized area on the X-ray diffractogram).

Extraction of starch from rice mature endosperm for amylopectin chain-length distribution was performed according to Yao et al. (2005). The chain-length distributions of  $\alpha$ -polyglucans from endosperm were analyzed using the capillary electrophoresis methods of O'Shea and Morell (1996).

Amylose content was determined with the simplified method developed by Juliano (1971). Standard samples with different amylose levels, provided by China National Rice Research Institute (CNIRRI), were used to construct a standard curve.

The paste viscosity of ground milled rice flour was measured using a Micro Visco-Amylo-Graph (Brabender OHG, DUISBURG, Germany). The analysis was based on the American Association of Cereal Chemists (2000) standard method AACC 61-01 and 61-02.

## QTL mapping method

The likelihood ratio test based on stepwise regression (RSTEP-LRT), as used by (Wang et al. 2006), was applied to the CSSL population. RSTEP-LRT can be used for QTL mapping in a population consisting of non-idealized CSSLs in which each line harbored one or several segments from

the donor parent. Stepwise regression was used to select the most important segments for the trait of interest, and the likelihood ratio test was used to calculate the LOD score of each chromosome segment. This method was statistically equivalent to the standard *t*-test with idealized CSSL lines. A threshold LOD score of 4.06 was determined from 1,000 permutation tests at the level of significance (0.05) and applied to declare a QTL as significant. To improve mapping power, multicollinearity among markers or chromosome segments was reduced, following the suggestion of Wang et al. (2006).

## Molecular marker screening and gene annotation

DNA was extracted from fresh leaves of each plant following Dellaporta et al. (1983). PCR protocol was as described by Chen et al. (1997), with minor modifications. PCR products were separated on an 8% non-denaturing polyacrylamide gel and detected using the silver staining. InDel markers in specific genomic regions were developed from a BLASTN alignment between the genome sequences of *japonica* cv. Nipponbare and *indica* cv. 9311. PCR primers were designed with software Primer Premier 5.0 to generate 100-300 bp amplicons at  $\sim 20$  kb intervals across these regions, and tested with template of 9311 and C-51. Genomic sequence was obtained from the International Rice Genome Sequencing Project (IRGSP) (<http://www.rgp.dna.affrc.go.jp/IRGSP/index.html>). Gene annotation within specific genomic regions was carried out using RiceGAAS (<http://www.ricegaas.rgp.dna.affrc.go.jp>).

## Results

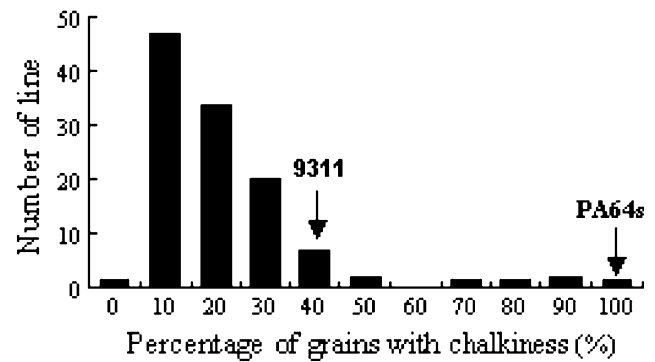
### PGWC QTL mapping in the 118 CSSL population

The two parents differ markedly for PGWC (Fig. 2), with PA64s showing consistently higher value than 9311 in two environments. In the CSSL population, PGWC ranged from 5 to 99.5%, with a discontinuity at 60% (Fig. 3). All but five CSSL (C-51, -52, -62, -23, -92) had a low PGWC, similar to that of 9311. The genetic, environmental and genotype  $\times$  environment interaction effects on PGWC were all significant across the three environments ( $P < 0.001$ ), but the genetic effect was far much greater than either of the other two (Table 1). Two QTL were identified—*qPGWC-6* on chromosomes 6 and *qPGWC-7* on chromosome 7 (Table 2). *qPGWC-6* is associated with a LOD score of 21.99 and PVE (% phenotypic variance explained) of 19.18%. Its map position places it close to RM190, which is known to be closely linked to *Wx* (Temnykh et al. 2000; McCouch et al. 2002). *qPGWC-7* has a LOD score of 27.75 and a PVE of 28.18%, and is

linked to RM234. The positive alleles at both loci were inherited from PA64s, increasing PGWC by 26.19 and 22.63%, respectively (Table 2). In lines C-23 and C-92, the PA64s chromosomal segment harboring *qPGWC-6* replaced the homologous segment of 9311. Similarly, the PA64s segment harboring *qPGWC-7* (defined by RM234) was present in lines C-51, C-52 and C-62 (Fig. 2), which are all associated with a significantly ( $P < 0.001$ ) higher PGWC than 9311 in at least two of the three environments. As the genetic background of C-51 was the closest to that of 9311, it was selected for comparisons of physical and chemical attributes, and as the parent of a population for fine mapping of *qPGWC-7*.

#### Physical and chemical characterization of the C-51 kernels

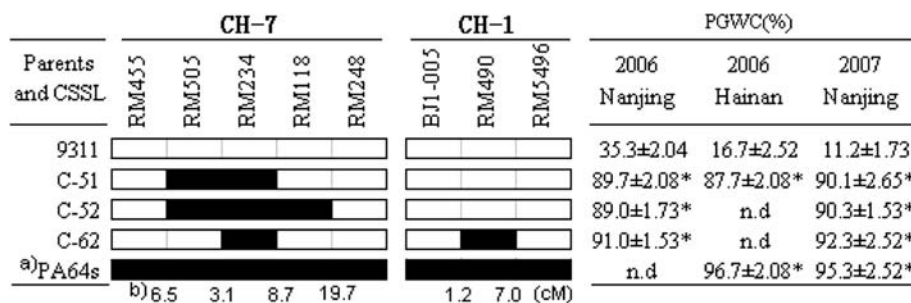
C-51 had a white-belly endosperm, markedly different from that of 9311, though both had similar grain size (Fig. 4a). SEM analysis showed the C-51 starch granules were typical of the chalky endosperm type, being round and loosely packed, and very different from densely packed, polyhedral starch granules of 9311 (Fig. 4b). No significant differences were observed the amylose contents of C-51 and 9311 grain (Table 3). The starch granules of C-51 and 9311 showed a typical A-type X-ray diffraction pattern (Fig. 4c), but the degree of crystallinity of C-51 was significantly ( $P < 0.05$ ) lower than that of 9311, and all four main peaks at  $2\theta$  were shifted slightly (Table 3; Fig. 4c). The amylopectin chain-length distribution patterns [degree of polymerization (DP) 8–30] were similar between C-51 and 9311 (Fig. 5a), but there were significantly more chains with DP 7 ( $P < 0.05$ ), 31, 51 and 52 ( $P < 0.01$ ), and markedly fewer chains with DP 33, 34, 38, and 45–47 ( $P < 0.05$ ). The difference between chains increased with increasing DP (Fig. 5b). The paste viscosity of endosperm starch of C-51 and 9311 showed no significant difference (data not shown).



**Fig. 3** Frequency distribution of PGWC in the CSSL population and its parents, PA64s and 9311. Plants grown in Nanjing in 2006

#### Genetic analysis and primary mapping of *qPGWC-7*

An  $F_2$  population of 2,108 plants derived from C-51/9311 was continuously distributed (values ranging from 5 to 99%, data not shown), rather than producing the expected segregation. As this was thought likely to have resulted from experimental errors at planting, the experiment was repeated with 5,965  $F_2$  plants from the same cross, produced from ten  $F_1$  plants. Four hundred and three progeny randomly selected from a single  $F_1$  plant were used for segregation analysis. The PGWC distribution of the resulting  $F_2$  plants was continuous, but with two discontinuity at around 30 and 70%, respectively (Fig. 6; Wang and Gai 2001). These 403 plants could be classified as three components (5–30, 31–70, 71–100%), fitting the expected 1:2:1 segregation for a semi-dominant trait ( $\chi^2 = 2.97 < \chi^2_{0.05,2} = 5.59$ ). The PA64s segment on the long arm of chromosome 7 was delimited to a  $\sim 18.3$  cM interval between RM455 and RM118 (Fig. 7a). Of 40 SSR markers located in this genome region (Temnykh et al. 2000; McCouch et al. 2002; <http://www.gramene.org/>), ten were informative between 9311 and C-51 (Fig. 7b). From the 2,108  $F_2$  population, the 400 individuals with a PGWC below 20% were mapped with these SSR, resulting in the



**Fig. 2** Graphical genotype and PGWC of parents and selected CSSLs in three environments (mean  $\pm$  SD,  $n = 3$ ). **Black** (PA64s) and **white** (9311) bars denote the parental origin of chromosome segments. **a** PA64s is a thermo-sensitive genic male sterile line, becoming fertile when exposed to  $<23.5^\circ\text{C}$  during pollen development. The endosperm

phenotype of PA64s was obtained from plants grown under low temperature. **b** Genetic distance between adjacent markers (cM). \* Significant difference at  $P < 0.001$ , based on *t*-test. *n.d* Not determined



**Table 1** An analysis of variance to determine the contribution to PGWC of environment, genotype and their interaction

Source of variation	Degree of freedom	Mean square	F-value	Probability
Genotype	3	10,734.6	3,056.0	<0.0001
Environment <sup>a</sup>	2	102.2	29.1	<0.0001
Replication	2	5.4	1.5	0.24
Genotype × environment	6	127.2	36.2	<0.0001
Error	22	3.5		

<sup>a</sup> Including Nanjing in 2006, Hainan in 2006 and Nanjing in 2007

**Table 2** Putative QTL for PGWC identified by the RSTEP-LRT method in the CSSL population derived from PA64s and 9311

QTL	Chromosome	Donor segment	LOD score	A	PVE (%)	CSSL with the identified QTL
<i>qPGWC-6</i>	6	RM190	21.99	26.19	19.18	C-23,92
<i>qPGWC-7</i>	7	RM234	27.75	22.63	28.18	C-51,52,62

A and PVE denotes additive effect and percentage of phenotypic variation explained of each QTL, respectively

narrowing of the genetic interval containing *qPGWC-7* to ~1.2 cM, delimited by RM21930 and RM21945 (Fig. 7b).

We also performed analysis based on the data from these 403 individuals of the F<sub>2</sub> population to detect QTL using Windows QTL cartographer 2.0 (Wang et al. 2003). The analysis detected a QTL in the interval between RM21930 and RM21945 with a LOD score 48.8 and explaining 60.6% of phenotypic variation in this population, further confirming the location of the *qPGWC-7* locus.

#### High-resolution mapping of *qPGWC-7*

Based on a comparison of the genomic sequence of cv. Nipponbare and cv. 9311, the separation between RM21930 and RM21945 is ~368 kb, including the four overlapping BAC/PAC clones OSJNBb0018H10, OSJNBb0039M16, OSJNBb0040H10 and P0493C06 (Fig. 8). A combination of SSRIT (<http://www.gramene.org/microsat/>) searching and genome sequence alignment focused on this region generated a further five SSR and 18 InDel markers, of which one SSR and seven InDel markers were informative between 9311 and C-51 (Table 4). Thus, together with the markers RM21930 and RM21945, ten markers were available for fine mapping in the extreme phenotype subset of 400 of the 2,108 F<sub>2</sub> grown in Hainan in 2006, and 2,821 of the 5,965 grown in Nanjing in 2007. RM21938 and InDels 1 and 15 co-segregated with *qPGWC-7*, with five recombinant events between InDel 14 and *qPGWC-7*, and two between InDel 3 and *qPGWC-7*. Lines N1 to N11, which harbour the 9311 allele at RM21938 and InDels 1 and 15, had a low PGWC, and N12 to N19, which carry PA64s alleles at these loci, had a high PGWC (Fig. 9). Thus *qPGWC-7* lies within a 44 kb region of BAC clone OSJNBb0040H10, bordered by InDels 14 and 3 (Fig. 8).

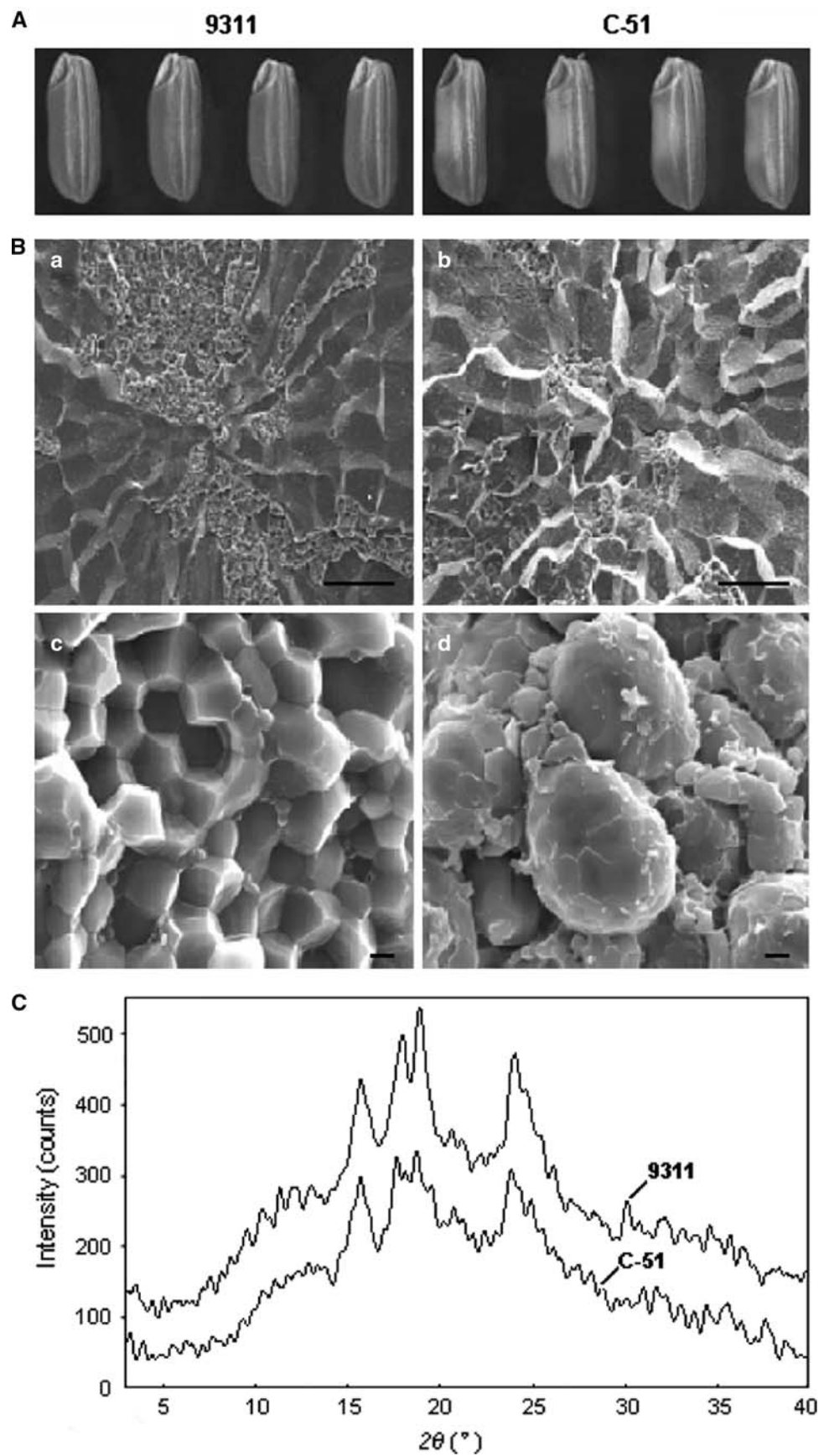
#### Putative genes in the 44-kb DNA fragment

Gene prediction analysis of the 44-kb DNA sequence containing *qPGWC-7* identified thirteen putative open reading frames (ORF). Of these, three (ORF 1, ORF 10, ORF12) are of unknown function, the remaining ones consist of a putative COBRA-like one protein precursor (BRITTLE CULM1-like six protein), a putative COBRA-like six protein precursor (BRITTLE CULM1-like seven protein), a putative Mitochondrial import inner membrane translocase subunit tim22, two putative B12D proteins, a hypothetical protein similar to outer membrane protein involved in nutrient binding, a putative Alpha-1,4-glucan-protein synthase 1 (UDP-glucose:protein transglucosylase 1, UPTG 1), a putative zinc finger protein, a putative proline-rich protein MP5, and a hypothetical protein similar to blight resistance protein RGA3.

#### Discussion

Whole genome CSSL or near isogenic line populations have been successfully constructed for rice (Yano and Sasaki 1997; Kubo et al. 1999; Xiao et al. 2005; Ebitani et al. 2005), and have been an effective tool for QTL mapping and positional cloning (Yano et al. 2000; Takahashi et al. 2001; Kojima et al. 2002; Doi et al. 2004; Wan et al. 2006). Whole genome CSSL populations are advantageous in this context, because the confounding effects of variation in the genetic background are removed as a factor, since all the lines share the same background. This allows the critical chromosome(s) segment to be readily identified. Once this has been achieved, it becomes a straightforward task to generate an appropriate fine-mapping population, by crossing the critical CSSL once more with the recurrent parent. Finally,

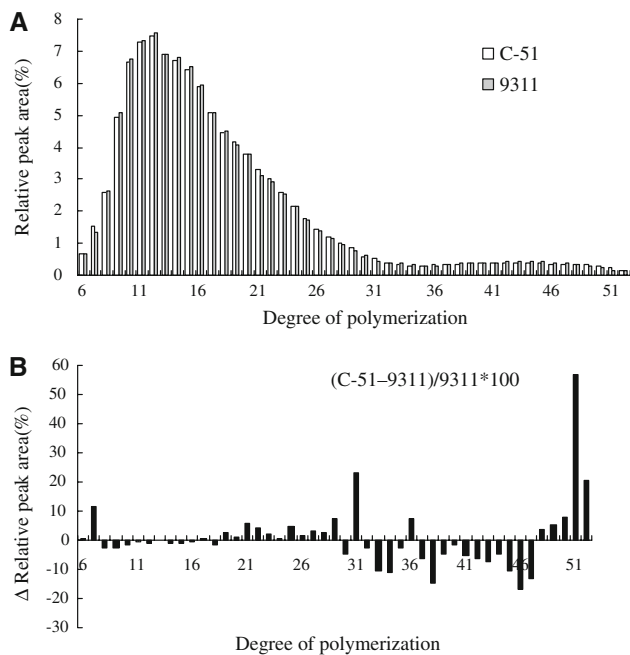
**Fig. 4** Starch granule morphology and structure of 9311 and C-51. **a** Grain morphology. **b** SEM images of starch granules in the mature endosperm. *a* and *c* 9311, *b* and *d* C-51. Bar represents 2  $\mu\text{m}$  in *a* and *b*, 10  $\mu\text{m}$  in *c* and *d*. **c** X-ray diffraction pattern of starch granules



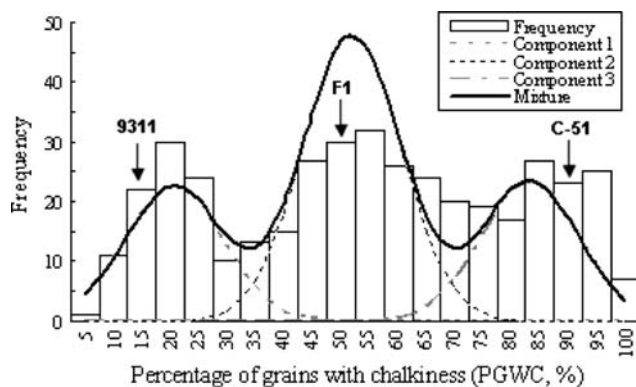
**Table 3** X-ray powder diffraction analysis and the determination of amylose content of C-51 and 9311

Parent and CSSL	Diffraction peaks at $2\theta$ (°)				Degree of crystallinity (%)	Amylose content (%)
	15.06	17.28	18.4	23.06		
9311	15.06	17.28	18.4	23.06	37.71 $\pm$ 2.12*	16.10 $\pm$ 0.457
C-51	15.04	16.94	17.98	22.76	20.05 $\pm$ 1.70	17.07 $\pm$ 0.312

\* Significant difference at 5% based on *t*-test

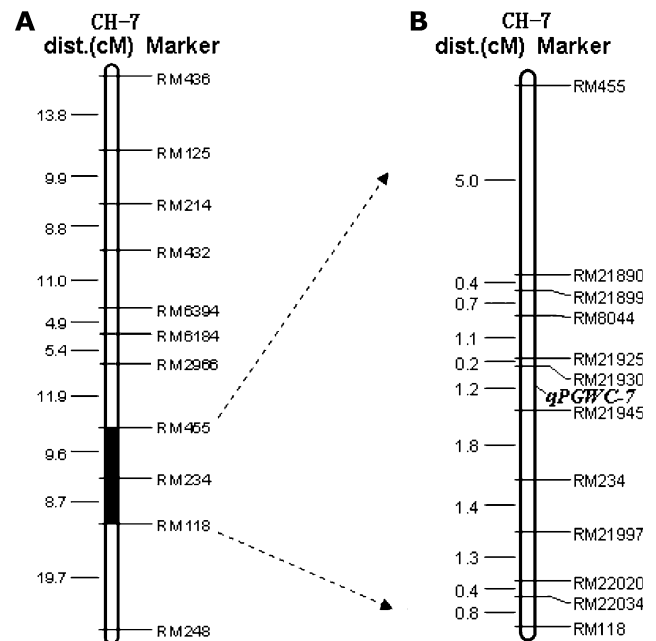


**Fig. 5** Distribution of chain length of  $\alpha$ -polysaccharides in C-51 and 9311 endosperm, as determined by capillary electrophoresis. **a** The distribution of  $\alpha$ -1,4-glucan chains in amylopectin, **b** the difference in amylopectin chain lengths between C-51 and 9311



**Fig. 6** Frequency distribution of the secondary  $F_2$  population from the cross C-51/9311. 403 plants were randomly selected from the one  $F_1$  plants growing in Nanjing in 2007

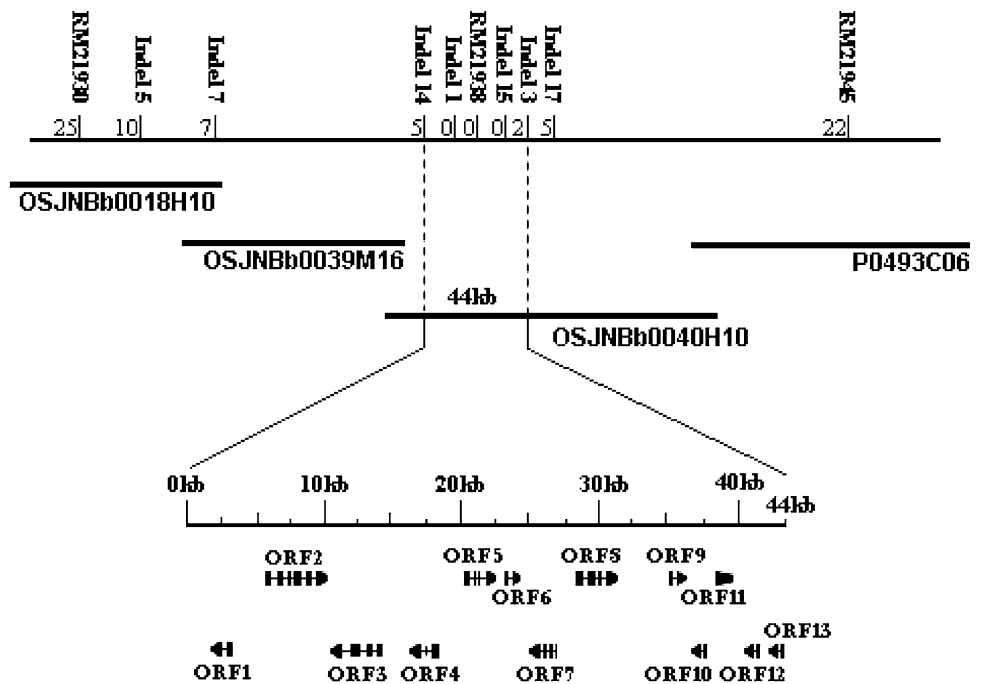
since all the individuals of this secondary mapping population are genetically even more homogeneous than was the CSSL population, most of the confounding non-genetic effects can be avoided.



**Fig. 7** Genetic location of *qPGWC-7*. **a** Genotype of C-51 (chromosomal segments derived from PA64s in black). **b** *qPGWC-7* maps to a 1.2 cM interval on chromosome 7

In the PA64s/9311 CSSL population, two strong PGWC QTL were identified. One (*qPGWC-6*) is linked to the *waxy* gene *Wx*, which has been reported previously using other populations (Tan et al. 2000; Li et al. 2003). Relevant QTL on chromosome 7 have been identified by Tan et al. (2000), who mapped a locus for white belly between R1245 and R1789, and by Huang (2006), who mapped a PGWC QTL to the interval R1245-R1789. These two intervals both include RM234 (Causse et al. 1994; McCouch et al. 2002), which we identified as being linked to *qPGWC-7*. In addition, PGWC of three lines harboring the QTL were significantly higher than that of 9311 in the three or two environments (Fig. 2,  $P < 0.001$ ), indicating *qPGWC-7* could stably express in different environments. Using the same strategy, Wan et al. (2005, 2006) assessed the stability of individual QTL using the CSSL harboring the target QTL grown in different environments. Thus, even though Yamakawa et al. (2007) have proposed that chalkiness character is labile with respect to the environment (especially temperature regime during the grain filling stage), it is clear that there is a substantial effect of genotype as well.

**Fig. 8** High-resolution genetic and physical maps of *qPGWC-7* and gene prediction in the critical region of chromosome 7. The figure denoted the number of the recombinant individuals corresponding to marker. ORF1 through13 denote open reading frames predicated by the RiceGAAS in the critical 44-kb DNA fragment



**Table 4** Primer sequences and the BAC/PAC location of markers location used for the fine mapping of *qPGWC-7*

Marker name	BAC/PAC location	Forward primer(5'-3')	Reversed primer(5'-3')
InDel 5	OSJNBb0018H10	CAGCTATGTGTAGCTTCG	GTGCTCATTGGGCGGTTT
InDel 7	OSJNBb0018H10 OSJNBb0039M16	AGAATTCAGATTCGTTGT	GTGTGTTTTCTGTGCCG
InDel 14	OSJNBb0040H10	TCATGATCAATGCACAA	AAGACTCCAAGACAAT
InDel 1	OSJNBb0040H10	TTGATTTCCCTGCTATAATACATGT	GGATCATCTGTCGTACCGTTCAAGCG
RM21938	OSJNBb0040H10	CCAAATTGCTTCTCGGATATAGG	CGGATTAGGGAGTTCGTGTTCCG
InDel 15	OSJNBb0040H10	AACCCATAAGAAGAGGAT	AATGAGGAAGGAAGCAAT
InDel 3	OSJNBb0040H10	CGTGTTTCGTTTCGTCGATTGCTGCT	GATGAGTCCCAAGAACAAAAGTACG
InDel 17	OSJNBb0040H10	CGATTGTTATTGGTATA	TATTGGTTGTAGGACTGT

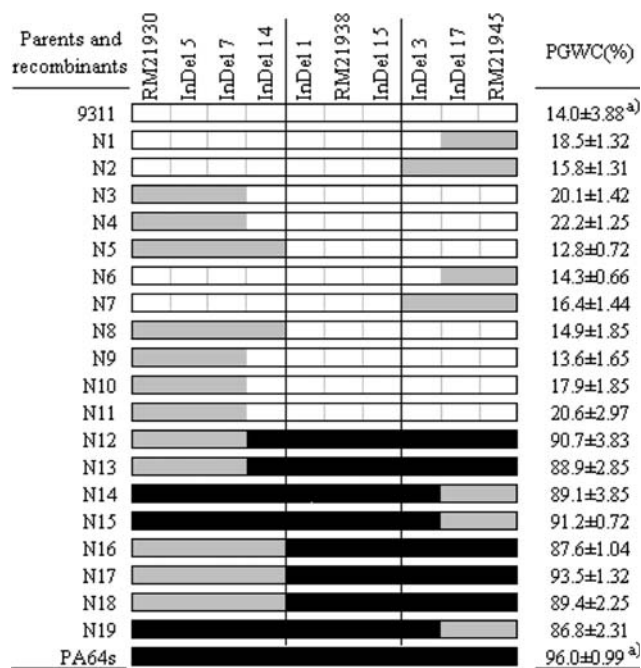
The distribution of PGWC in the CSSL population showed an obvious bias (Fig. 3). There were more individuals with low PGWC. This transgressive segregation of PGWC was also observed in the Asominori/IR24 CSSL population (Wan et al. 2005), and so did other chalkiness characteristics, i.e., area of chalkiness endosperm and degree of chalkiness endosperm (Wan et al. 2005). Other mapping populations, including F<sub>2,3</sub>, RIL and DH populations, also segregated transgressively for PGWC (Tan et al. 2000; He et al. 1998). This phenomenon appears in different populations, resulting possibly from effects of genetic recombination or epistasis or minor-effect genes.

Fujita et al. (2007) described a starch synthase III (*SSIIIa*) mutant with white-core endosperm, in which the structure and components of the endosperm starch were profoundly altered. Although the difference in degree of crystallinity between C-51 and 9311 minors the difference between this mutant and its wild type, the difference

between the viscosity profiles and amylopectin structure of the starch in C-51 and 9311 was, in contrast, relatively minor. 9311 and C-51 do not appear to differ allelically at the *SSIIIa* locus (data not shown). Thus the pattern of accumulation of the starch granules, the low degree of crystallinity and the altered amylopectin make-up of C-51 starch must flow from the action of a different gene, presumably in the *qPGWC-7* region, which contains no known rice starch synthases. Taken together, *qPGWC-7* is the first fine-mapped gene for white-belly endosperm in rice.

We are seeking to identify the gene responsible for chalkiness, using a transgenic complementation approach, in order to gain an understanding of the mechanisms underlying the formation and regulation of endosperm texture. The fine mapping approach has suggested 13 possible candidate genes, although some of these can probably be eliminated on the basis of their putative function. Meanwhile, the close linkage established between





**Fig. 9** Molecular marker genotypes and phenotypes of the recombinants for fine mapping. The white, black and grey bars denote the marker genotype of 9311, PA64 s and heterozygote, respectively. N1 and N2 were the individuals from the F<sub>2</sub> population planted in Hainan in 2006. N3 to N19 were the individuals from the F<sub>2</sub> population planted in Nanjing in 2007. a) mean of PGWC in Hainan in 2006 and Nanjing in 2007

*qPGWC-7* and a number of simple molecular markers can be exploited for quality breeding in rice.

**Acknowledgments** This research was supported by the National Natural Science Foundation of China (30500315), 863 Program of China (2006AA10Z1A5, 2006AA100101, 2007AA10Z116), National Science and Technology Supporting Program (2006BAD13B01), Jiangsu Province Agricultural Germplasm Gene Pool Program (sx(2007)g02) and the 111 project (B08025).

## References

- American Association of Cereal Chemists (2000) Approved methods for the AAC, 10th edn. Method 61-01 and Method 61-02. The Association, St. Paul
- Causse MA, Fulton TM, Cho YG, Ahn SN, Chunwongse J, Wu K, Xiao J, Yu ZH, Ronald PC, Hamington SE, Second G, McCouch SR, Tanksley SD (1994) Saturated molecular map of the rice genome based on an interspecific backcross population. *Genetics* 138:1251–1274
- Cheetham NWH, Tao LP (1998) Variation in crystalline type with amylose content in maize starch granules: an X-ray powder diffraction study. *Carbohydr Polym* 36:277–284
- Chen X, Temnykh S, Xu Y, Cho YG, McCouch SR (1997) Development of a microsatellite framework map providing genome-wide coverage in rice (*Oryza sativa* L.). *Theor Appl Genet* 95:553–567
- Cheng FM, Zhong LJ, Wang F, Zhang GP (2005) Differences in cooking and eating properties between chalky and translucent parts in rice grains. *Food Chem* 90:39–46

- Del Rosario AR, Briones VP, Vidal AJ, Juliano BO (1968) Composition and endosperm structure of developing and mature rice kernel. *Cereal Chem* 45:225–235
- Dellaporta SL, Wood J, Hicks JB (1983) A plant DNA mini preparation: version II. *Plant Mol Biol Rep* 1:19–21
- Doi K, Izawa T, Fuse T, Yamalouchi U, Kubo T, Shimatani Z, Yano M, Yoshimura A (2004) *Ehd1*, a B-type response regulator in rice, confers short-day promotion of flowering and controls FT-like gene expression independent of *Hdl*. *Genes Dev* 18:926–936
- Ebitani T, Takeuchi Y, Nonoue Y, Yamamoto T, Takeuchi K, Yano M (2005) Construction and evaluation of chromosome segment substitution lines carrying overlapping chromosome segments of indica rice cultivar ‘Kasalath’ in a genetic background of japonica elite cultivar ‘Koshihikari’. *Breed Sci* 55:65–73
- Fujita N, Yoshida M, Kondo T, Saito K, Utsumi Y, Tokunaga T, Nishi A, Satoh H, Park JH, Jane JL, Miyao A, Hirochika H, Nakamura Y (2007) Characterization of *SSIIa*-deficient mutants of rice: The function of *SSIIa* and pleiotropic effects by *SSIIa* deficiency in the rice endosperm. *Plant Physiol* 144:2009–2023
- Fujita S, Yamamoto H, Sugimoto Y, Morita N, Yamamori M (1998) Thermal and crystalline properties of waxy wheat (*Triticum aestivum* L.) starch. *J Cereal Sci* 27:1–5
- He P, Li SG, Li JS, Ma YQ, Qian Q, Wang WM, Chen Y, Zhu LH (1998) Mapping analyses for QTL associated some traits affect rice grain quality. *Chin Sci Bull* 43(16):1747–1750
- He P, Li SG, Qian Q, Ma YQ, Li JZ, Wang WM, Chen Y, Zhu LH (1999) Genetic analysis of rice grain quality. *Theor Appl Genet* 98:502–508
- Huang JX (2006) Genetic analysis and QTL mapping research of appearance quality traits in *indica* rice. Master thesis of Xiamen University (in Chinese, English abstract)
- Juliano BO (1971) A simplified assay for milling rice amylose. *Cereal Sci Today* 16:334–336
- Kang HG, Park SH, Matsuoka M, An GH (2005) White-core endosperm floury endosperm-4 in rice is generated by knockout mutations in the C4-type pyruvate orthophosphate dikinase gene (*OsPPDKB*). *Plant J* 42:901–911
- Koh HJ, Son YH, Heu MH, Lee HS, McCouch SR (1999) Molecular mapping of a new genic male-sterility gene causing chalky endosperm in rice (*Oryza sativa* L.). *Euphytica* 106:57–62
- Kojima S, Takahashi Y, Kobayashi Y, Monna L, Sasaki T, Araki T, Yano M (2002) *Hd3a*, a rice ortholog of the *Arabidopsis FT* gene, promotes transition to flowering downstream of *Hdl* under short-day conditions. *Plant Cell Physiol* 43:1096–1105
- Kubo T, Nakamura K, Yoshimura A (1999) Development of a series of *indica* chromosome segment substitution lines in japonica background of rice. *Rice Genet Newsl* 16:104–106
- Li JM, Xiao JH, Grandillo S, Jiang LY, Wan YZ, Deng QY, Yuan LP, McCouch SR (2004) QTL detection for rice grain quality traits using an interspecific backcross population derived from cultivated Asian (*O. sativa* L.) and African (*O. glaberrima* S.) rice. *Genome* 47:697–704
- Li ZF, Wan JM, Xia JF, Zhai HQ (2003) Mapping quantitative trait loci underlying appearance quality of rice grains (*Oryza sativa* L.). *Acta Genet Sin* 30:251–259
- McCouch SR, Teytelman L, Xu Y, Lobos KB, Clare K, Walton M, Fu B, Maghirang R, Li Z, Xing YZ, Zhang Q, Kono I, Yano M, Fjellstrom R, Declerck G, Schneider D, Cartinhour S, Ware D, Stein L (2002) Development and mapping of 2240 new SSR markers for rice (*Oryza sativa* L.). *DNA Res* 9:199–207
- Nagato K, Ebata M (1959) Studies on white-core rice kernel II on the physical properties of the kernel. *Proc Crop Sci Soc Jpn* 28:46–50
- NSPRC (National Standard of People Republic of China) (1999) High quality paddy, GB/T17891-1999, Standards Press of China

- O'Shea MG, Morell MK (1996) High resolution slab gel electrophoresis of 8-amino-1, 3, 6-pyrenetrisulfonic acid (APTS) tagged oligosaccharides using a DNA sequencer. *Electrophoresis* 17:681–688
- Satoh H, Omura T (1981) New endosperm mutations induced by chemical mutagen in rice, *Oryza sativa* L. *Jpn J Breed* 31:316–326
- Shi CH, Wu JG, Lou XB, Zhu J, Wu P (2002) Genetic analysis of transparency and chalkiness area at different filling stages of rice (*Oryza sativa* L.). *Field Crops Res* 76:1–9
- Singh N, Kaur L, Sandhu KS, Kaur J, Nishinari K (2006) Relationships between physicochemical, morphological, thermal, rheological properties of rice starches. *Food Hydrocolloids* 20:532–542
- Singh N, Sodhi NS, Kaur M, Saxenda SK (2003) Physicochemical, morphological, thermal, cooking and textural properties of chalky and translucent rice kernels. *Food Chem* 82:433–439
- Takahashi Y, Shomura A, Sasaki T, Yano M (2001) *Hd6*, a rice quantitative trait locus involved in photoperiod sensitivity, encodes the  $\alpha$  subunit of protein kinase CK2. *Proc Natl Acad Sci USA* 98:7922–7927
- Tan YF, Xing YZ, Li JX, Yu SB, Xu CG, Zhang QF (2000) Genetic bases of appearance quality of rice grains in Shanyou 63, an elite rice hybrid. *Theor Appl Genet* 101:823–829
- Temnykh S, Park WD, Ayres N, Cartinour S, Hauck N, Lipovich L, Cho YG, Ishii T, McCouch SR (2000) Mapping and genome organization of microsatellite sequence in rice (*Oryza sativa* L.). *Theor Appl Genet* 100:697–712
- Wan XY, Wan JM, Jiang L, Wang JK, Zhai HQ, Weng JF, Wang HL, Lei CL, Wang JL, Zhang X, Cheng ZJ, Guo XP (2006) QTL analysis for rice grain length and fine mapping of an identified QTL with stable and major effects. *Theor Appl Genet* 112:1258–1270
- Wan XY, Wan JM, Weng JF, Jiang L, Bi JC, Wang CM, Zhai HQ (2005) Stability of QTL for rice grain dimension and endosperm chalkiness characteristics across eight environments. *Theor Appl Genet* 110:1334–1346
- Wang J, Gai J (2001) The inheritance of resistance of soybeans to agromyzid beanfly (*Nelanaomyza sojae zehntaer*)-mixed major gene and polygenes genetical analysis. *Euphytica* 122:9–18
- Wang S, Basten CJ, Zeng ZB (2003) Windows QTL cartographer, version 2.0. Department of Statistics, North Carolina State University, Raleigh (<http://statgen.ncsu.edu/qtlcart/WQTLCart.htm>)
- Wang JK, Wan XY, Crossa J, Crouch J, Weng JF, Zhai HQ, Wan JM (2006) QTL mapping of grain length in rice (*Oryza sativa* L.) using chromosome segment substitution lines. *Genet Res Camb* 88:93–104
- Xiao YH, Liu LL, Jiang L, Lu CG, Yu CY, Zhang WW, Zuo JS, Zhai HQ, Wan JM (2005) Development of the chromosome segment substitution lines (CSSL) derived from a hybrid rice cross, PA64s/9311 with super high yield potential. *Rice Genet Newsl* 22:17–19
- Yamakawa H, Hirose T, Kuroda M, Yamaguchi T (2007) Comprehensive expression profiling of rice grain filling-related genes under high temperature using DNA microarray. *Plant Physiol* 144:258–277
- Yano M, Katayose Y, Ashikari M, Yamanouchi U, Monna L, Fuse T, Bala T, Yamamoto K, Umehara Y, Nagamura Y, Sasaki T (2000) *Hd1*, a major photoperiod sensitivity quantitative trait locus in rice, is closely related to the *Arabidopsis* flowering time gene. *Plant Cell* 12:2473–2483
- Yano M, Sasaki T (1997) Genetic and molecular dissection of quantitative traits in rice. *Plant Mol Biol* 35:145–153
- Yao Y, Guiltinan MJ, Thompson DB (2005) High-performance size-exclusion chromatography (HPSEC) and fluorophore-assisted carbohydrate electrophoresis (FACE) to describe the chain-length distribution of debranched starch. *Carbohydr Res* 340:701–710
- Yu J, Hu S, Wang J, Wong GK, Li S, Liu B, Deng Y, Dai L, Zhou Y, Zhang X, Cao M, Liu J, Sun J, Tang J, Chen Y, Huang X, Lin W, Ye C, Tong W, Cong L, Geng J, Han Y, Li L, Li W, Hu G, Huang X, Li W, Li J, Liu Z, Li L, Liu J, Qi Q, Liu J, Li L, Li T, Wang X, Lu H, Wu T, Zhu M, Ni P, Han H, Dong W, Ren X, Feng X, Cui P, Li X, Wang H, Xu X, Zhai W, Xu Z, Zhang J, He S, Zhang J, Xu J, Zhang K, Zheng X, Dong J, Zeng W, Tao L, Ye J, Tan J, Ren X, Chen X, He J, Liu D, Tian W, Tian C, Xia H, Bao Q, Li G, Gao H, Cao T, Wang J, Zhao W, Li P, Chen W, Wang X, Zhang Y, Hu J, Wang J, Liu S, Yang J, Zhang G, Xiong Y, Li Z, Mao L, Zhou C, Zhu Z, Chen R, Hao B, Zheng W, Chen S, Guo W, Li G, Liu S, Tao M, Wang J, Zhu L, Yuan L, Yang H (2002) A draft sequence of the rice genome (*Oryza sativa* L. *ssp. indica*). *Science* 296:79–92